

BOTTLE LIFTING HAND TRUCK DLB150

Technical qualities:

The Bottle Lifting Hand Truck has a chain that will hold the bottle while lifting and carrying.

Its bearing balls facilitate the move and thus a precise placement.

Its self-locking winch and galvanized steel cable \varnothing 4 mm ensure strength while lifting.



Ref. 300 733

The Bottle Lifting Hand Truck DLB 150 is ideal for handling and storing your bottles, adopt it!

- Adapts to all environments : workshops, construction sites...
- EPOXY painted steel strong structure
- Light and handy
- Space-saving
- Electro-galvanized self-locking winch
- Bearing balls for placement

Applications:

- Handling in workshops or construction sites
- Welding bottles lifting
- Handling of large extinguishers

Characteristics :

- Maximum working load: 150 kg
- Lifting height: 3 à 650 mm
- Rise by crank turn: 65 mm
- Wheels \varnothing 200 mm⁽¹⁾
- Manual electro-galvanized self-locking winch
- Galvanized steel cable \varnothing 4 mm
- Platform width: 310 mm (utile)
- Depth: 310 mm (utile)
- Congestion (L x l x H) : 600 x 635 x 1344 mm
- Tare weight : 36 kg

(1) : optionnal inflatable wheels kit
Reference : 220 486

Applications:



Dimensional Drawings:

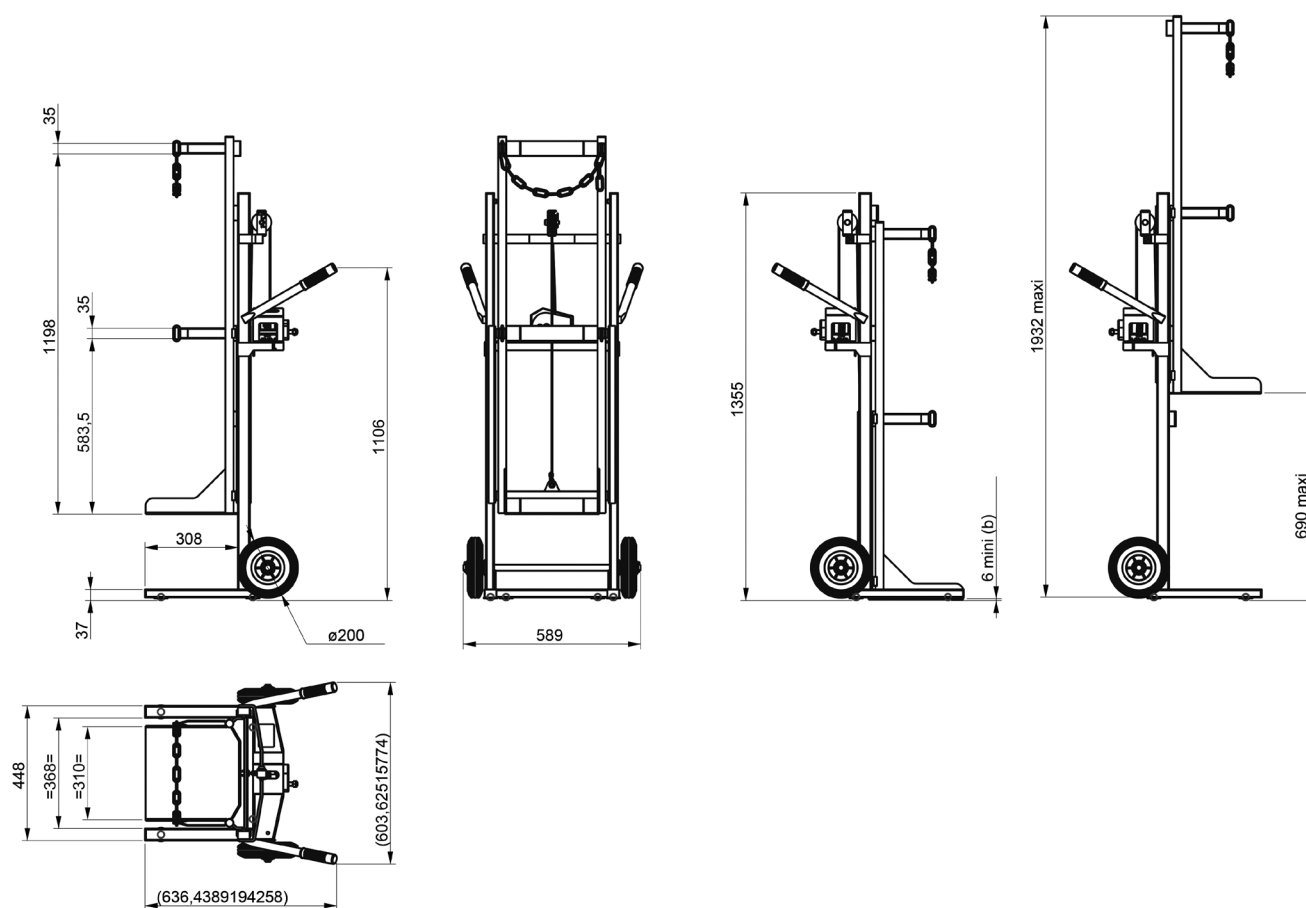

Terms of use

The user is responsible for defining the products to be adapted to its own use. TELIP takes charge of submitting accurate and updated information. However, as part of the continuous improvement of its products, TELIP reserves the right to proceed with frequent modifications without warning. Therefore, TELIP cannot guarantee the accuracy and current reality of information on its products. All transactions are subject to general terms and conditions of sales and transportation. These conditions are available upon request and downloadable on the website www.telip.fr.

TELIP
MANUTENTION ET LEVAGE

TELIP
2, rue Andrée Reigner - Z. I. La Bougeoire
35 130 La Guerche de Bretagne
FRANCE

Tél. : 02 99 96 17 16
Fax : 02 99 96 17 26

contact@telip.fr
www.telip.fr