

## STEEL MINI STACKER MG 100

### Technical qualities:

Versatile, the Steel Mini stacker MG 100 can be used for many handling operations in the industrial sector.

Very robust, and with a very low center of gravity, its mechano-welded painted steel chassis provides perfect stability for safe use and movement.

Featuring 4 directional wheels, including 2 brake wheels, and ergonomic handles, the handling of the MG 100 Steel Mini Stacker is optimal.

Safe and very simple operation thanks to its self-braked manual lift winch. The sheaving of the lifting cable allows the operator to lift a large load while greatly limiting the effort to be provided on the crank.

Standard, the MG 100 Steel Mini Stacker is equipped with forks bolted to the apron. *Center distance between forks axes adaptable on demand.*

As an option, many accessories are available: platform, V-Bed platform, Europe tray holders, single arm, crane arm...

**NEW VERSION:** Total height reduced to 2.02 metres making it easier to pass through a standard door frame.

*Available in stainless steel (ref. 300 198).*

### Characteristics:

- Capacity: 100 kg
- Lifting height: 75 à 1600 mm
- Rise by turn of crank: 25 mm
- zinc-plated steel self-braked winch
- Cable galvanized steel  $\varnothing$  4 mm
- Swivelling wheels  $\varnothing$  60 mm
- Forks section (L x W x H) : 510 x 40 x 15 mm
- Center distance of forks axes: 460 mm
- Clutter (L x W x H): 975 x 755 x 2020 mm
- Net weight: 56 kg

*The load should be evenly distributed over the forks or on the surface of the platform.*

*The centre of gravity of the load must be positioned with a maximum deflected 300 mm from the mobile apron.*

*In compliance with the machine Directive 2006/42/CE*



### Ref. 300 195

*Thanks to its versatility and numerous options, the **MG 100 Steel Mini Stacker** solves a majority of handling problems in the industry.*

- Extremely robust and stable chassis
- Handy thanks to its 4 directional wheels
- Ergonomic handles for easy move
- Quality and reliable manual lifting winch
- Reduced effort thanks to its sheaving cable
- Forks bolted to apron, removable
- Versatile, many options available

### Applications:

- Handling miscellaneous loads in the industry
- Extra workstation
- Elevation and removal of trays, cartons, etc.
- Setting up coils on machine, etc...

For further information about this product:

**contact@telip.fr**

## Accessories:



Movable platform  
Ref: 300196



Transversal V-Bed  
Ref: 300197



Longitudinal V-Bed  
Ref: 300201



Europe tray holder  
Ref: 300202



Single arm  
Ref: 300203



Crane arm  
Ref: 300204

## Dimensional Drawings:

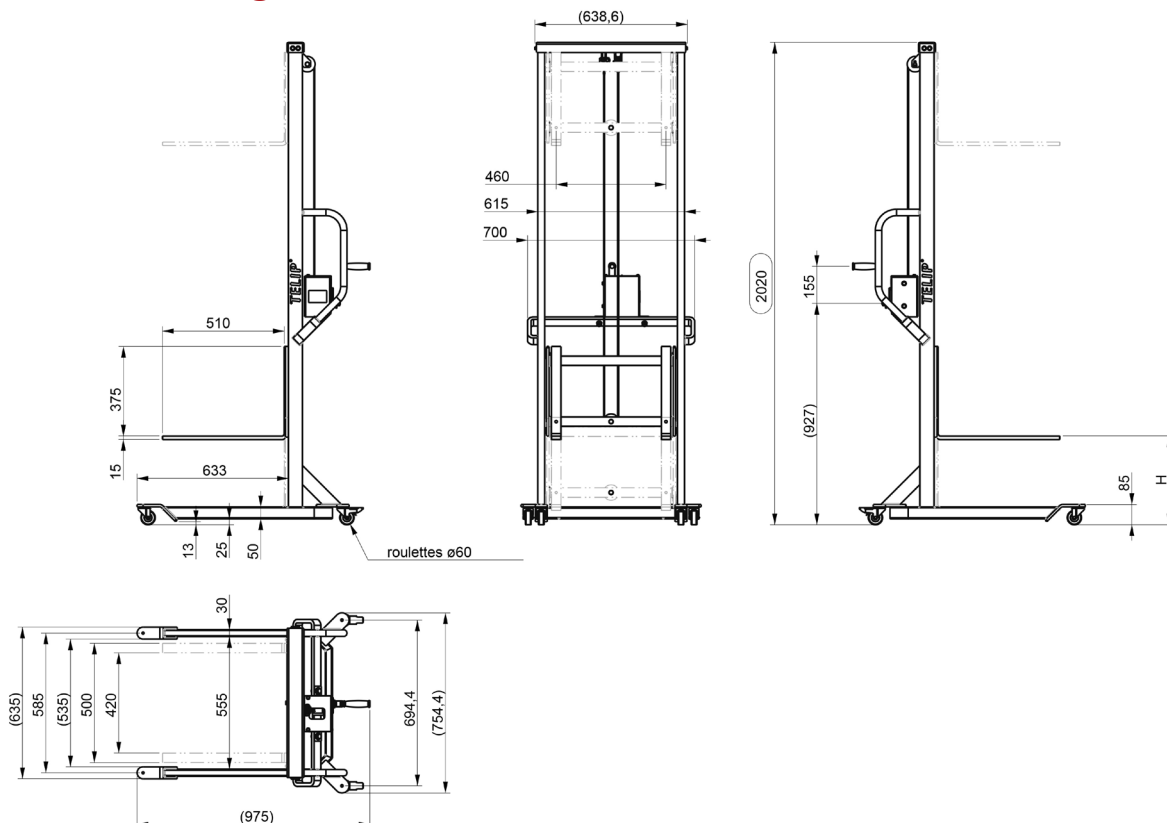

### Terms of use

The user is responsible for defining the products to be adapted to its own use. TELIP takes charge of submitting accurate and updated information. However, as part of the continuous improvement of its products, TELIP reserves the right to proceed with frequent modifications without warning. Therefore, TELIP cannot guarantee the accuracy and current reality of information on its products. All transactions are subject to general terms and conditions of sales and transportation. These conditions are available upon request and downloadable on the website [www.telip.fr](http://www.telip.fr).

**TELIP**  
MANUTENTION ET LEVAGE

TELIP  
2, rue Andrée Reigner - Z. I. La Bougeoire  
35 130 La Guerche de Bretagne  
FRANCE

Tél. : 02 99 96 17 16  
Fax : 02 99 96 17 26

contact@telip.fr  
[www.telip.fr](http://www.telip.fr)