

OFF-ROAD LIFTER ETT 250

Technical qualities:

Equipped with rubber tyres, with 2 rear caster wheels with brakes, the off-road lifter moves on every type of ground.

Its strong epoxy paint steel structure and its manual hydraulic lifting device procure safety and comfort of use while lifting loads.

Its reduced clutter allows passing in narrow places without alterations, as for example the crossing of 83cm wide doors (or more).

For more adaptability, its gripping forks are adjustable sideways and enable the handling of half-pallets (normalised) in their length.

Especially developed to accompany you on your construction sites or set up sites, the off-road lifter can be loaded in a utility vehicle; the forks and the stringers are easily removable; no tools are necessary.

A blocking device allows maintaining the ram in lower position, indispensable especially when the equipment is layed down in a vehicle.



Ref. 300 840

The Off-Road Lifter ETT 250 is the ideal solution for lifting and handling loads in a workshop or construction sites.

- Adapts to all ground: workshop, construction sites...
- Capacity up to 250 kg
- Lifting height: 70 to 840 mm
- Portable in a utility vehicle
- 4 rubber tyres, with 2 rear caster wheels with brakes
- Manually adjustable descent speed

Applications:

- Handling in workshops
- Lifting of heavy loads
- Lifting of half-pallets in a vehicle
- Moving of loads on a construction site...

Characteristics:

- Maximum working load : 250 kg
- Lifting height: 70 to 840 mm
- Rubber tyres \varnothing 200 mm (1)
- Fork section (L x W x H): 775 x 70 x 50 mm
- Inside distance between forks: 175 à 400 mm
- Outside distance between forks: 315 à 540 mm
- Inside distance between stringers: 625 mm
- Cluttler (L x W x H) : 1190 x 783 x 1250 mm
- Maximum total height (2): 1325 mm
- Tare weight: 77 kg

(1) : rigid rubber wheels upon request

(2) : corresponds to the total height of the lifter, when the forks are in upper position.

For further information about this product:

contact@telip.fr

Its Key Strengths:



Rubber tyres \varnothing 200 mm, with 2 castor wheels with brakes



Manual hydraulic lifting device, reliable and easy to use.



Strong ram, guided by 4 encapsulated balls bearing

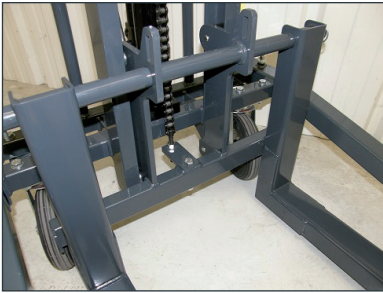

Adjustable fork sideways and easily removable, without tools.



Stingers easy to remove, to facilitate storage.



Ram blocking device, to secure during transportation in vehicle.

Dimensional Drawings:

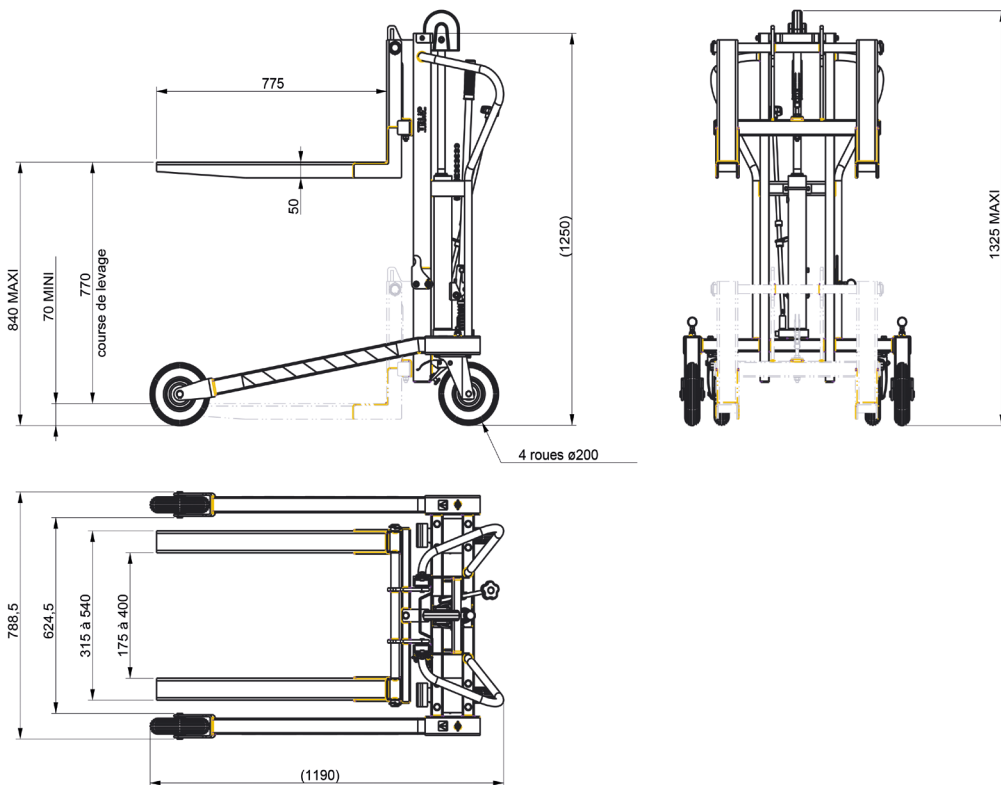

Terms of use

The user is responsible for defining the products to be adapted to its own use. TELIP takes charge of submitting accurate and updated information. However, as part of the continuous improvement of its products, TELIP reserves the right to proceed with frequent modifications without warning. Therefore, TELIP cannot guarantee the accuracy and current reality of information on its products. All transactions are subject to general terms and conditions of sales and transportation. These conditions are available upon request and downloadable on the website www.telip.fr.

TELIP
MANUTENTION ET LEVAGE

TELIP
2, rue Andrée Reigner - Z. I. La Bougeoire
35 130 La Guerche de Bretagne
FRANCE

Tél. : 02 99 96 17 16
Fax : 02 99 96 17 26

contact@telip.fr
www.telip.fr