

LOAD LIFTER HAND TRUCK DLC 250

Technical qualities:

The wheel axle is movable and lockable to ease the tipping of the hand truck in case of heavy loads.

Thanks to a removable platform, the load can either be lifted by forks or the platform depending on the need.

The self-braking winch secures the user and saves a considerable amount of time.

The load is lifted thanks to a $\varnothing 6$ galvanised steel cable.



Ref. 300 209

The Load Lifter Hand Truck DLC 250 has a movable wheel axle allowing the tipping of a heavy load with minimal efforts.

- EPOXY painted steel strong structure
- Capacity up to 250 Kg
- Increased stability thanks to side skids
- Platform or forks to lift the load
- Manual sel-locking winch

Applications:

- Handling in workshop
- Lifting of heavy loads

Characteristics:

- Maximum working load: 250 kg
- Lifting height: 20 à 700 mm
- Rise by handwheel revolution: 40 mm
- Wheels \varnothing 200 mm (1)
- Manual electro-galvanized self-locking winch
- Galvanized steel cable \varnothing 6 mm
- Fork sections (L x l x H): 360x 40 x 20 mm
- Fork length: 360 mm - Center distance: 250 mm
- Congestion (L x l x H): 700 x 600 x 1160mm
- Platform dimensions (L x W) : 429 x 550 mm
- Tare weight: 46 kg

(1): optionnal inflatable wheels kit
Reference : 220 486

Dimensional Drawings:

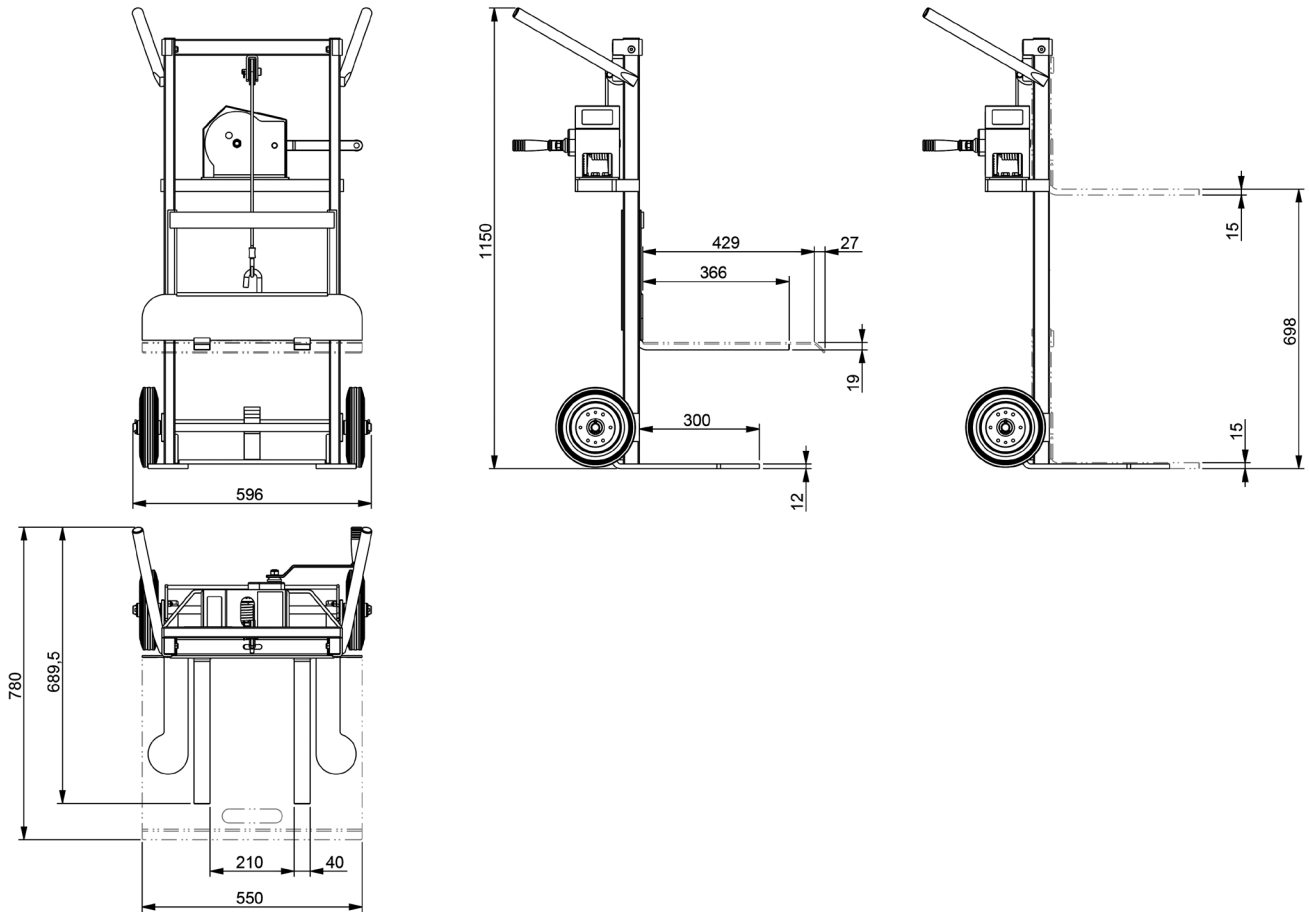

Terms of use

The user is responsible for defining the products to be adapted to its own use. TELIP takes charge of submitting accurate and updated information. However, as part of the continuous improvement of its products, TELIP reserves the right to proceed with frequent modifications without warning. Therefore, TELIP cannot guarantee the accuracy and current reality of information on its products. All transactions are subject to general terms and conditions of sales and transportation. These conditions are available upon request and downloadable on the website www.telip.fr.

TELIP
MANUTENTION ET LEVAGE

TELIP
2, rue Andrée Reigner - Z. I. La Bougeoire
35 130 La Guerche de Bretagne
FRANCE

Tél. : 02 99 96 17 16
Fax : 02 99 96 17 26

contact@telip.fr
www.telip.fr