

RACK BEAM LIFTER

LPC

Technical qualities:

The LPC Rack Beam Lifter is fitted with an eye for lifting the load and a 360 ° rotating platform for positioning beams, lintels or various other loads.

The beam lifter is supplied with a 300mm riser tube as standard, reaching a maximum height of 3m.

Very precise thanks to the rack-and-pinion lifting system, controlled manually via a removable crank.

To facilitate storage, transport or even on-site delivery, the beam lifter is fully foldable and / or removable, quickly and without tools.

Recommended use of 2 beam lifters for mounting beams or very long loads (900kg maximum distributed over the 2 beam lifters).



Ref. 300 741

The LPC Rack Beam Lifter can be used for handling and / or lifting beams, lintels or various other loads.

- Extremely handy thanks to its 4 directional castors and its low weight
- Hot-dip galvanized steel structure guaranteeing a long service life
- Precise rack lifting system
- Fully foldable and / or removable
- Extension tube supplied as standard

Applications:

- Handling and lifting of beams
- Installation of lintels
- Lifting of various loads up to 600kg

Characteristics:

- Maximum capacity of use : 600kg on 1 beam lifter
900kg on 2 beam lifters
- Lifting height without extension: 1,10 to 2,70m
- Lifting height with extension: 1,40 to 3,00m
- Platform dimensions (L x W x H): 360 x 220 x 110 mm
- Transport dimensions (L x W x H): 1600 x 800 x 600 mm
- Empty weight: 70 kg

Use:

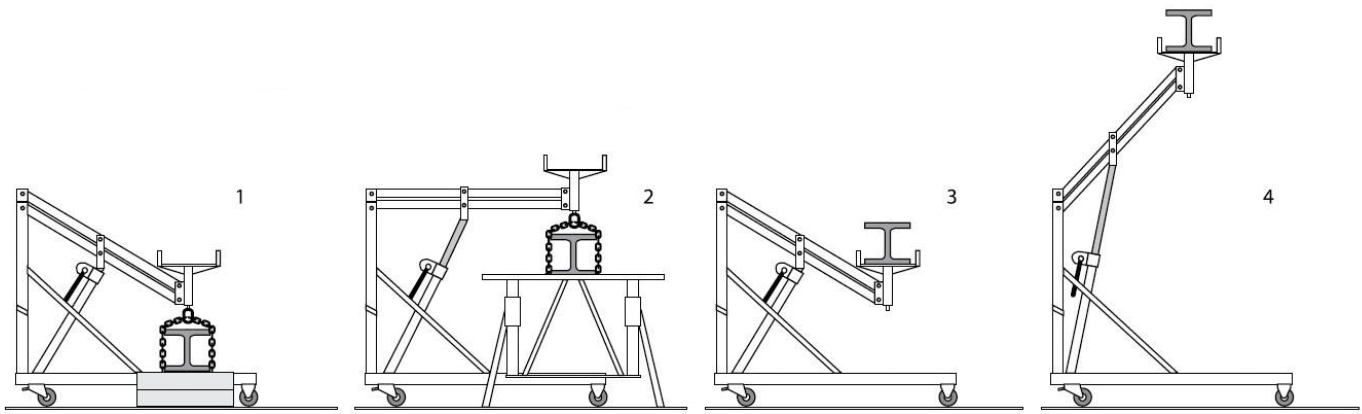

Dimensional Drawing:

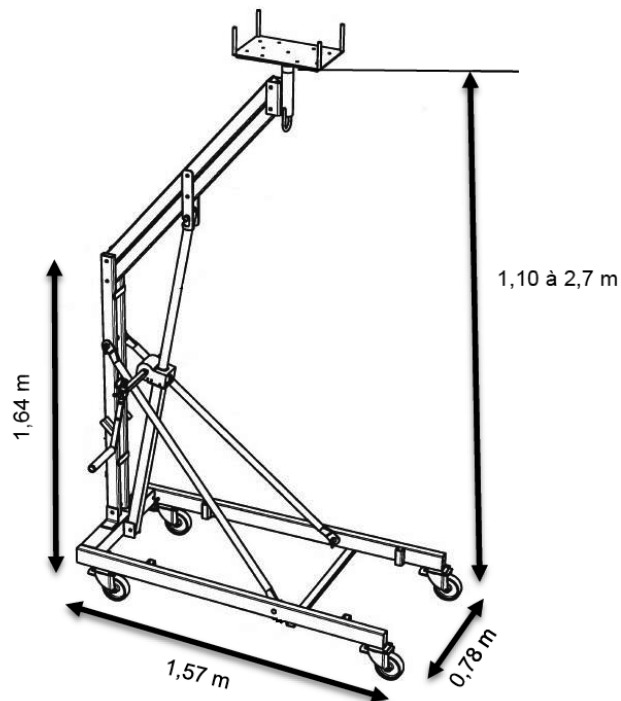

Terms of use

The user is responsible for defining the products to be adapted to its own use. TELIP takes charge of submitting accurate and updated information. However, as part of the continuous improvement of its products, TELIP reserves the right to proceed with frequent modifications without warning. Therefore, TELIP cannot guarantee the accuracy and current reality of information on its products. All transactions are subject to general terms and conditions of sales and transportation. These conditions are available upon request and downloadable on the website www.telip.fr.

TELIP
MANUTENTION ET LEVAGE

TELIP
2, rue Andrée Reigner - Z. I. La Bougeoire
35 130 La Guerche de Bretagne
FRANCE

Tél. : 02 99 96 17 16
Fax : 02 99 96 17 26

contact@telip.fr
www.telip.fr