

HEATER LIFTING HAND TRUCK

DLR 150

Technical qualities:

To easily and safely lift a heater while installing or uninstalling, including in the least accessible places.

The crank controls the lifting of the platform thanks to a $\varnothing 4$ galvanized steel cable.

The self-locking winch is also made of galvanized steel.



Ref. 300 205

The Heater Lifting Hand Truck DLR 150 facilitates handling of your heaters.

- EPOXY painted steel strong chassis
- Light
- Handy
- High quality manual lifting winch

Applications:

- Handling on construction sites
- Lifting of heavy loads
- Renovation works

Characteristics:

- Maximum working load: 150 kg
- Lifting height: 20 à 480 mm
- Rise by crank turn: 65 mm
- Wheels \varnothing 200 mm (1)
- Galvanized steel cable \varnothing 4 mm
- Height: 1007 mm
- Width: 600 mm
- Length: 540 mm
- Platform dimensions: L. 440 x p. 220 mm
- Tare weight: 26 kg

(1) : optional inflatable wheels kit
Reference : 220 486

Dimensional Drawings:

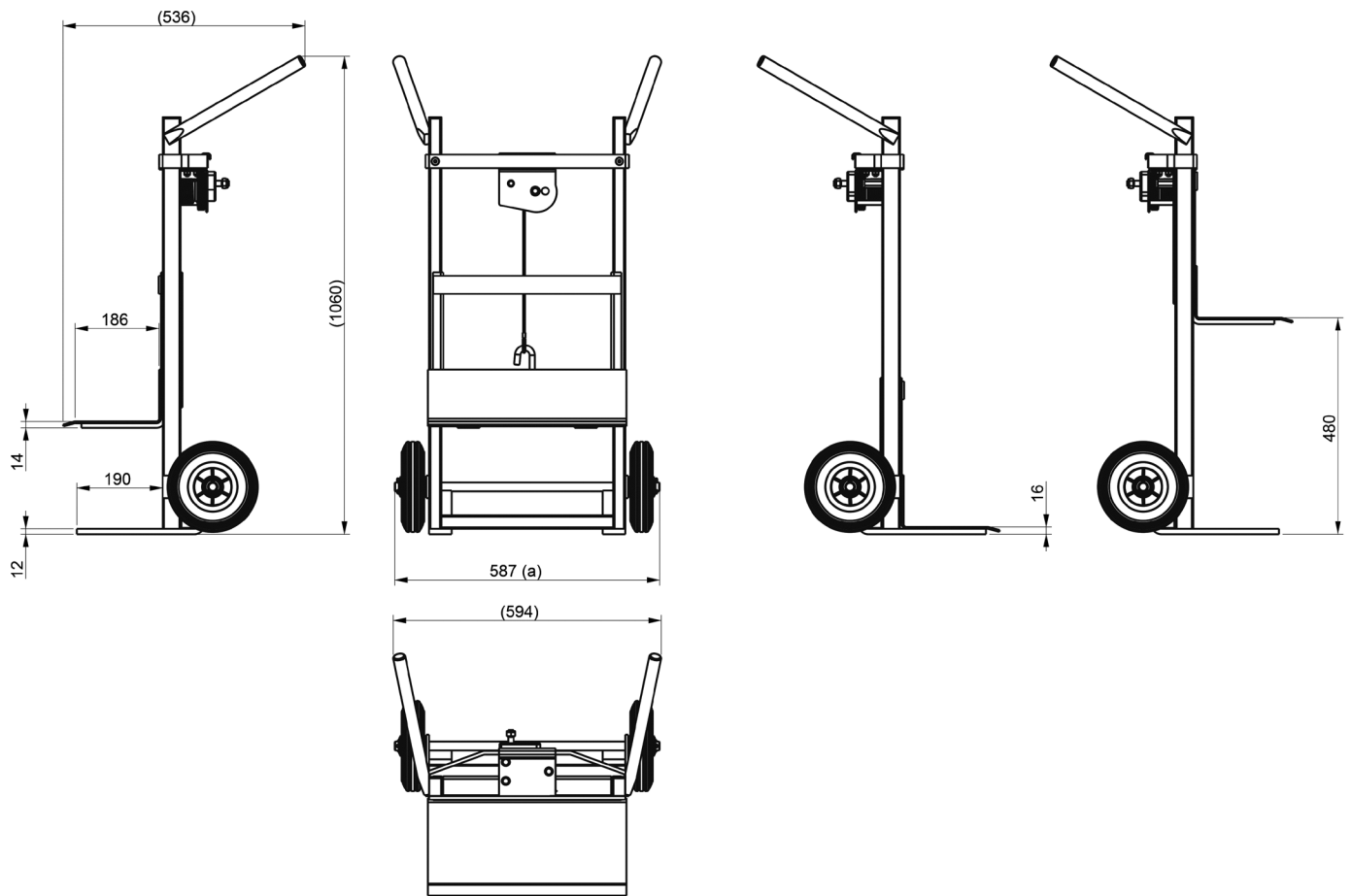

Terms of use

The user is responsible for defining the products to be adapted to its own use. TELIP takes charge of submitting accurate and updated information. However, as part of the continuous improvement of its products, TELIP reserves the right to proceed with frequent modifications without warning. Therefore, TELIP cannot guarantee the accuracy and current reality of information on its products. All transactions are subject to general terms and conditions of sales and transportation. These conditions are available upon request and downloadable on the website www.telip.fr.

TELIP
MANUTENTION ET LEVAGE

TELIP
2, rue Andrée Reigner - Z. I. La Bougeoire
35 130 La Guerche de Bretagne
FRANCE

Tél. : 02 99 96 17 16
Fax : 02 99 96 17 26

contact@telip.fr
www.telip.fr