

# STAINLESS STEEL MINI STACKER

## MG 100

### Technical qualities:

The MG 100 stainless steel Mini Stacker is versatile thanks to its wide range of accessories.

Robust and resistant 304L stainless steel chassis.

These 4 directional wheels make it very handy.

Comes standard with a zinged steel winch, it can also receive a 316L stainless steel winch <sup>(1)</sup>.

Its easily removable forks offer the possibility to modify their spread on request.

The wide handles allow, regardless of the size of the user, a comfortable grip.

The sheaving of the lifting cable allows a large load to be lifted while limiting the effort to be produced.



### Ref. 300 198

*The MG 100 stainless steel Mini Stacker is very versatile, thanks to its many accessories it solves various handling problems.*

- Stainless steel version
- 4 swivel wheels, 2 of which are braked
- Removable forks
- Multi-position handles
- Sheaving cable

### Applications:

- Handling in workshops
- Handling in difficult areas
- Handling of coil, tray, etc...
- Extra workstation

### Characteristics:

- Capacity: 100 kg
- Lifting height: 87 à 1740 mm
- Rise by turn of crank: 25 mm
- Self-braked hand-cranked winch
- 316 stainless steel cable ø 4 mm
- Swivelling wheels ø 60 mm
- Forks section (L x W x H): 520 x 40 x 15 mm
- Center distance of forks axes: 460 mm
- Clutter (L x W x H) : 970 x 720 x 2143 mm
- Net weight: 56 kg

(1) : available in option

## Accessories:



**Movable platform**  
Ref : 900132



**Longitudinal V-Bed**  
Ref : 900134



**Transversal V-Bed**  
Ref : 900135



**Single arm**  
Ref sur demande

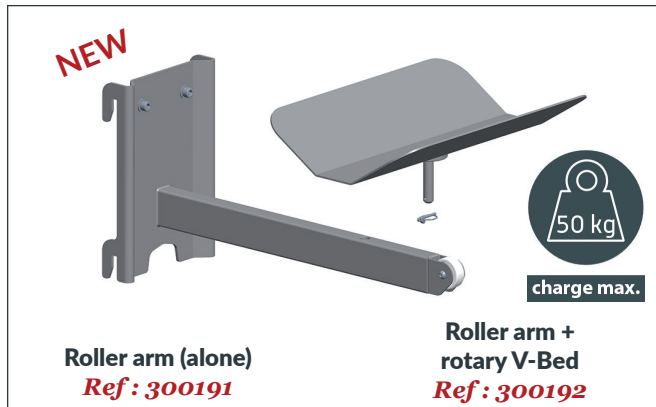

**Stainless steel winch**  
Ref : 350037

**On demand:**

- Adaptations
- Specific dimensions
- Tailor-made studies & adaptations

**Contact us...**

## Dimensional Drawings:

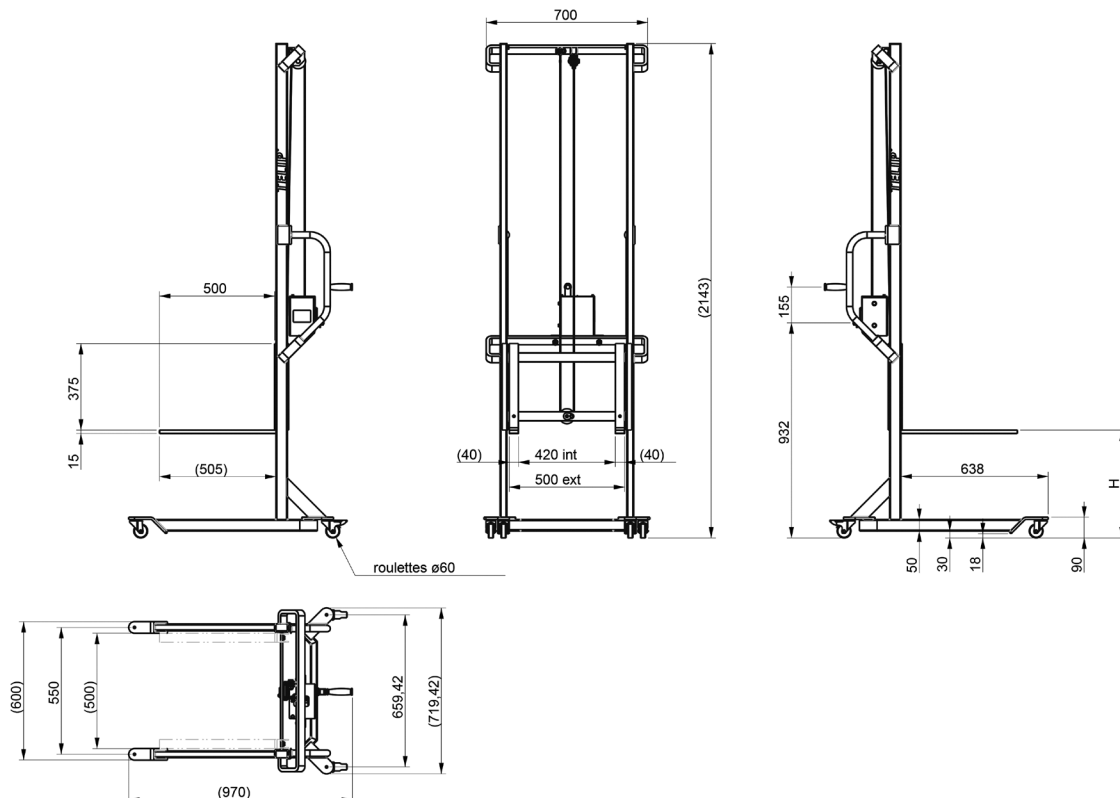

### Terms of use

The user is responsible for defining the products to be adapted to its own use. TELIP takes charge of submitting accurate and updated information. However, as part of the continuous improvement of its products, TELIP reserves the right to proceed with frequent modifications without warning. Therefore, TELIP cannot guarantee the accuracy and current reality of information on its products. All transactions are subject to general terms and conditions of sales and transportation. These conditions are available upon request and downloadable on the website [www.telip.fr](http://www.telip.fr).

**TELIP**  
MANUTENTION ET LEVAGE

TELIP  
2, rue Andrée Reigner - Z. I. La Bougeoire  
35 130 La Guerche de Bretagne  
FRANCE

Tél. : 02 99 96 17 16  
Fax : 02 99 96 17 26

contact@telip.fr  
[www.telip.fr](http://www.telip.fr)