

STAINLESS STEEL LOAD MANIPULATOR MCH 150

Technical qualities:

The MCH 150 stainless steel load manipulator has a light structure in 304L stainless steel.

With removable plastic protectors, it respects the integrity of the object you are handling.

The fixed polyamide rollers facilitate passage under the machine.

The multi-position handles allow whatever the size of the user, a comfortable grip.

Equipped as standard with a galvanized steel manual lifting winch, it can be optionally fitted with a 316L stainless steel winch.



Ref. 300 718

The MCH 150 Stainless Steel Load Manipulator has been specially developed for the food industry.

- Robust mechanically welded structure
- Black plastic protectors, removable
- Self-braking manual winch in galvanized steel (1)
- Lightweight and stable

Applications:

- Handling in the food industry
- Handling in difficult environments
- Cold and humid environments

Characteristics:

- Maximum working load: 150 kg
- Lifting height: 60 à 1400 mm
- Raised by crank turn: 65 mm
- At the rear, swivel castors \varnothing 60 mm with brake
- At the front, polyamide rollers (fixed) \varnothing 50 mm
- Fork section (L x W x H): 455 x 20 x 35mm
- Center distance between forks: 330 mm
- Dimensions (L x W x H): 890 x 461 x 1650 mm
- Maximum total height: 2016 mm
- Empty weight: 30 kg

(1): optional, self-braking manual winch in 316 L stainless steel

Accessories:



Platform
Ref: 300 737



V-Bed platform
Réf: 300 738



316 L stainless steel winch
Ref: 350 037

Dimensional Drawings:

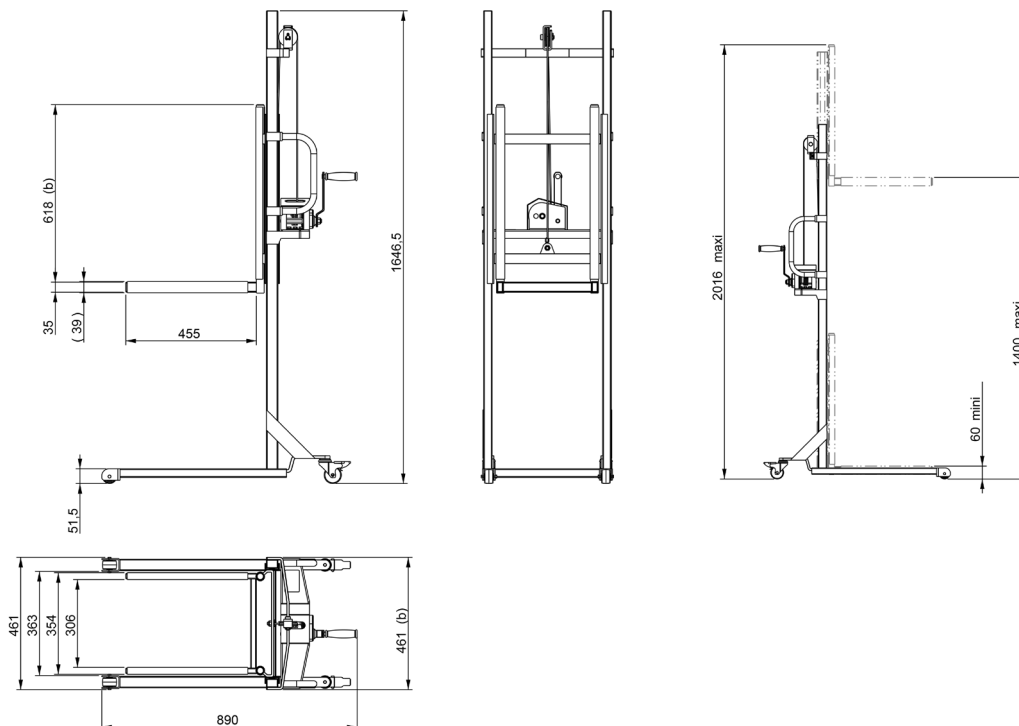

Terms of use

The user is responsible for defining the products to be adapted to its own use. TELIP takes charge of submitting accurate and updated information. However, as part of the continuous improvement of its products, TELIP reserves the right to proceed with frequent modifications without warning. Therefore, TELIP cannot guarantee the accuracy and current reality of information on its products. All transactions are subject to general terms and conditions of sales and transportation. These conditions are available upon request and downloadable on the website www.telip.fr.

TELIP
MANUTENTION ET LEVAGE

TELIP
2, rue Andrée Reigner - Z. I. La Bougeoire
35 130 La Guerche de Bretagne
FRANCE

Tél. : 02 99 96 17 16
Fax : 02 99 96 17 26

contact@telip.fr
www.telip.fr