

## APPLIANCE HAND TRUCK

### DEM 150

### Technical qualities:

The Appliance Hand Truck DEM 150 is a transportation hand truck.

The specific cut of the loading platform enables the handling of appliances by sparing water output devices.

This hand truck is especially designed for transportation of heavy and cumbersome loads such as refrigerators, washing machines, etc.



### Ref. 300 732

*The Appliance Hand Truck DEM 150 is ideal for handling household appliance thanks to its cut.*

- EPOXY painted steel strong structure
- Easy to operate
- Specific cut for water output devices
- Light

### Applications:

- Handling of heavy loads
- Handling of cumbersome loads

### Characteristics:

- Maximum working load: 150 kg
- Solid rubber tyres  $\varnothing$  200 mm (1)
- Ergonomic handles length 120 mm
- Platform (L x P): 400 x 170 mm
- Platform thickness: 4 mm
- Congestion (L x l x H): 475 x 415 x 1090mm
- Tare weight: 12 kg

(1) : optional inflatable wheels kit  
Reference 220 486

For further information about this product:

**contact@telip.fr**

## Dimensional Drawings:

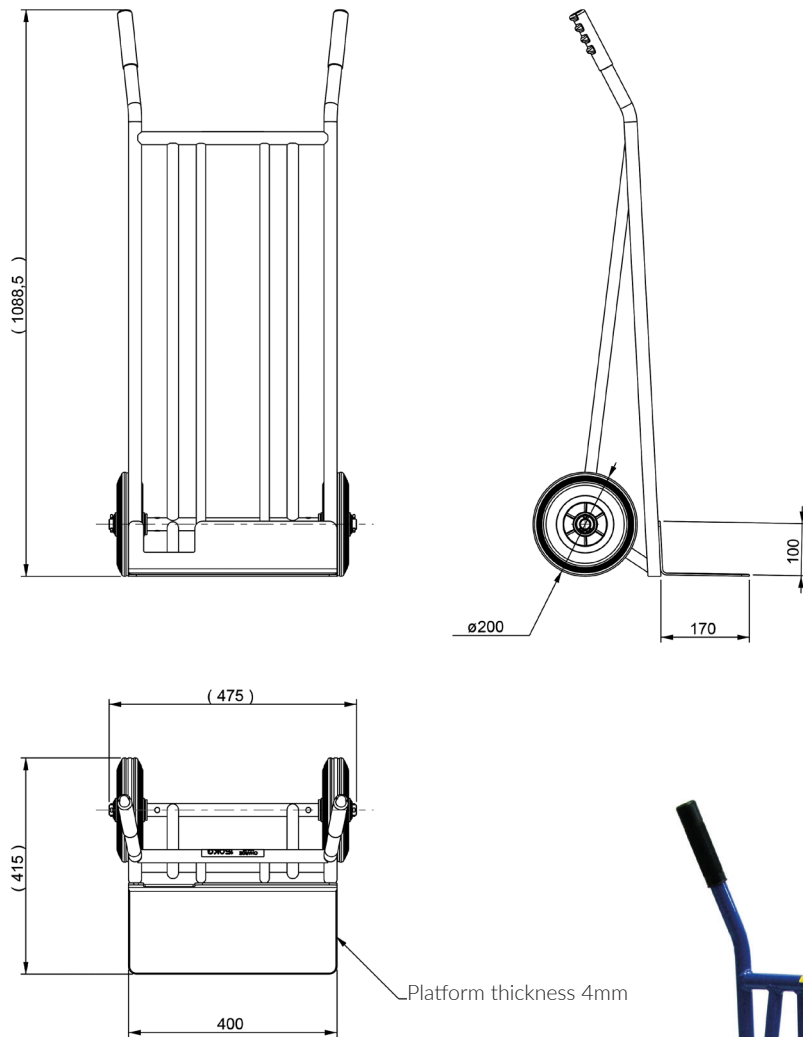

### Terms of use

The user is responsible for defining the products to be adapted to its own use. TELIP takes charge of submitting accurate and updated information. However, as part of the continuous improvement of its products, TELIP reserves the right to proceed with frequent modifications without warning. Therefore, TELIP cannot guarantee the accuracy and current reality of information on its products. All transactions are subject to general terms and conditions of sales and transportation. These conditions are available upon request and downloadable on the website [www.telip.fr](http://www.telip.fr).

**TELIP**  
MANUTENTION ET LEVAGE

TELIP  
2, rue Andrée Reigner - Z. I. La Bougeoire  
35 130 La Guerche de Bretagne  
FRANCE

Tél. : 02 99 96 17 16  
Fax : 02 99 96 17 26

[contact@telip.fr](mailto:contact@telip.fr)  
[www.telip.fr](http://www.telip.fr)