

Technical qualities:

Thanks to its low weight, reduced congestion and its 4 handling balls positioned under the chassis, handling and accuracy of DMS 150 are incomparable.

Its EPOXY painted steel strong structure and high quality lifting winch provide safety and use comfort.

It can easily be transported in a utility vehicle to help you on your construction sites.

The DMS 150 is supplied as standard with an extension allowing to increase the lifting height up to 1,75m. The extension is manually removable and a stocking position is provided on the chassis.

The extra-flat baseplate allows to easily go under a machine or a piece of furniture.

The forks and the moving part are covered with plastic protectors (removable) not to mark the load.

For high or cylindrical loads, the DMS 150 is equipped with a 3m retaining strap.

The DMS 150 is very adaptable and can be equipped with several accessories (see at the back).



Ref. 300 187

The DMS 150 is a multipurpose lifting trolley that can carry, position and lift cumbersome loads up to 150 kg.

- EPOXY painted steel strong chassis
- High quality manual lifting winch
- Efficient, light and easy to use
- Accurate positioning thanks to handling balls assembled under the chassis
- Removable standard extension to lift up to a height of 1,75 m
- Protectors not to mark the load

Applications:

- Transport, repair of household appliances
- Installing or uninstalling electric boilers
- Installation of kitchen furnitures
- Portable workstation

Characteristics:

- Maximum working load: 150 kg
- Lifting height without extension: 40 à 1100 mm
- Lifting height with extension: 40 à 1750 mm
- Rise by crank turn: 65 mm
- Rubber tyred rigid wheels (1) : ø 200 mm
- Fork section (H x l): 35 x 20 mm
- Width: 600 mm
- Length: 840 mm
- Hight (2): 1355 / 1995 mm
- Tare weight: 40 kg

(1) : optional inflatable wheels kit
Référence : 220 486

(2) : stated height without / with extension
when the forks are in upper position, the total height becomes bigger

For further information about this product:

contact@telip.fr

Accessories (optional):



V-bed (roll handling)
Ref: 300 189

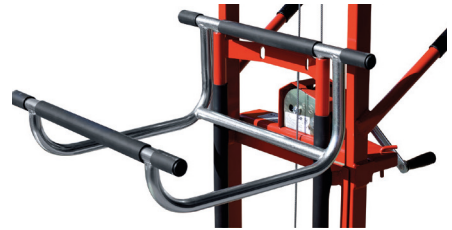

Cradle (water heating handling)
Ref: 300 190



Platform 450 x 350 mm (LxW)
Ref: 300 188



Inflatable wheels kit ø200
Ref: 220 486

Dimensional Drawings:

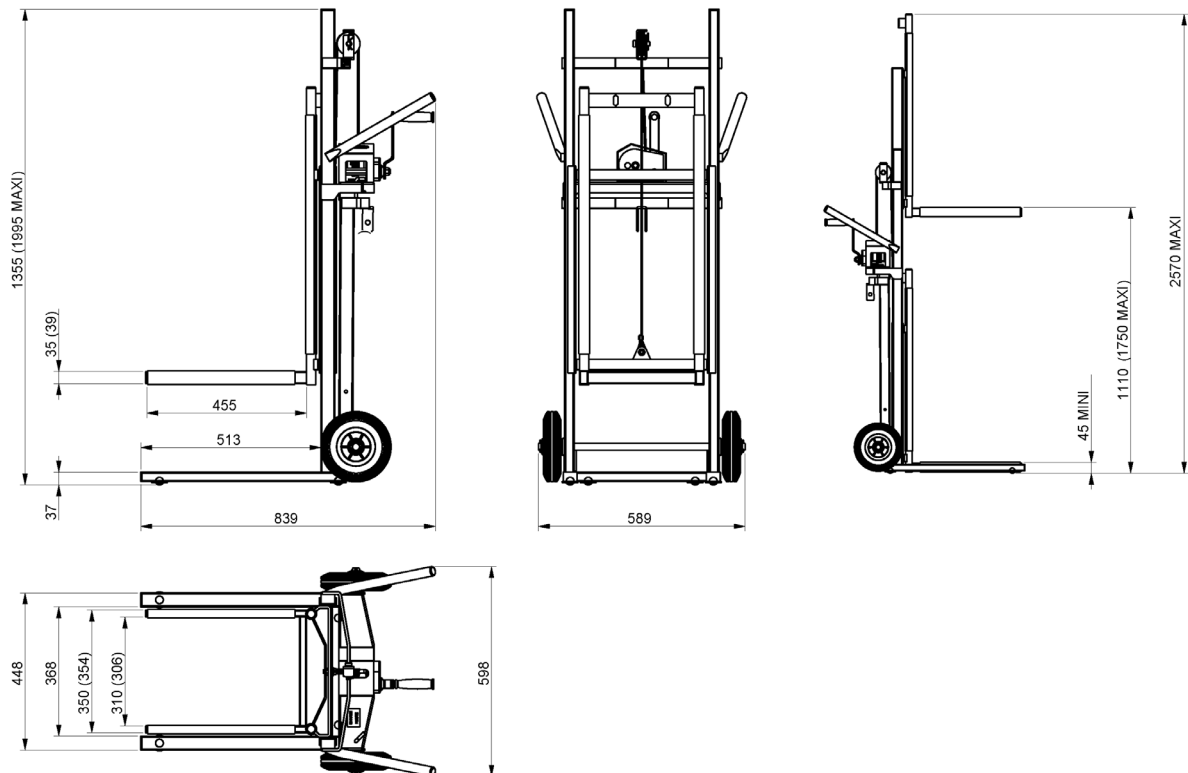

Terms of use

The user is responsible for defining the products to be adapted to its own use. TELIP takes charge of submitting accurate and updated information. However, as part of the continuous improvement of its products, TELIP reserves the right to proceed with frequent modifications without warning. Therefore, TELIP cannot guarantee the accuracy and current reality of information on its products. All transactions are subject to general terms and conditions of sales and transportation. These conditions are available upon request and downloadable on the website www.telip.fr.

TELIP
MANUTENTION ET LEVAGE

TELIP
2, rue Andrée Reigner - Z. I. La Bougeoire
35 130 La Guerche de Bretagne
FRANCE

Tél. : 02 99 96 17 16
Fax : 02 99 96 17 26

contact@telip.fr
www.telip.fr